

INSTALLATION AND OPERATING MANUAL

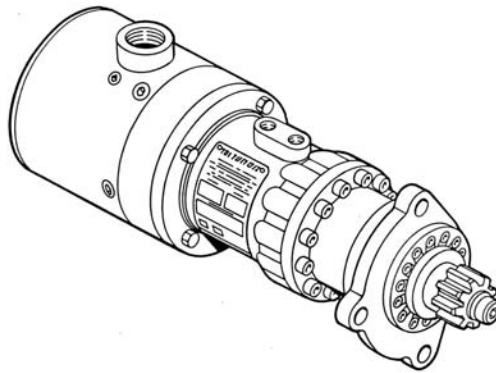

MODEL: T30-Y **TURBOTWIN** Engine Air Starter



TABLE OF CONTENTS

SECTION	SUBJECT	PAGE
1.0	General Information	1
2.0	Orientation of Starter	1
3.0	Installing the Starter	3
4.0	Starter Operation	4
5.0	Model T30 Warranty	6
6.0	Operator's Trouble Shooting Guide	7

LIST OF ILLUSTRATIONS

FIGURE	TITLE	PAGE
1	Envelope drawing	8
2	Installation Diagram	9
3	T30 Performance Curve, Air	10
4	T30 Performance Curve, Gas	10

1.0 GENERAL INFORMATION

This manual provides instructions for the installation and operation of the TDI Turbotwin™ Models T30-Y and T30-U air starters. If there are questions not answered by this manual, please contact your TDI Turbotwin™ distributor or dealer for assistance.

The T30-Y and T30-U models are turbine driven air starters with a pre-engage starter drive. They are best suited for diesel engines up to 20 Liters (1220 CID) or gasoline engines up to 28 Liters (1709 CID). Model T30-Y is designed for installation on engines that use an SAE 1, 2, or 3 mounting pad. Model T30-U is a basic configuration with options to allow SAE 1, 2, or 3, or special flange mounts.

The T30 Series starters are suited to operate within a wide range of inlet air pressures and ambient temperatures. The engine size and parasitic loading will determine the exact minimum pressure that will ensure reliable starting.

The T30 Series starters are designed for operation with compressed air or natural gas. Moderate amounts of foreign matter or liquid in the air stream will normally not adversely affect T30 Series starters. As with all other TDI Turbotwin™ models, no lubrication is required in the supply air.

You need to review the rest of this manual before installing your TDI Turbotwin™ T30 Series starter.

1.1 WARNINGS, CAUTIONS, & NOTES

Throughout this manual, certain types of information will be highlighted for your attention:

WARNING - used where injury to personnel or damage to the equipment is possible.

CAUTION - used where there is the possibility of damage to the equipment.

NOTE - used to point out special interest information.

1.2 INSTALLATION and SERVICE

The TDI Turbotwin™ T30 series starters provide distinct advantages of size and efficiency compared to electric motor, vane-type, or other turbine-type air starters. It is important to properly install the starter to receive full benefit of these advantages. Repair technicians or service organizations without turbine starter experience should not attempt to repair this machine until they receive factory approved training from TDI, or its representatives. Proper operation and repair of your TDI Turbotwin™ T30 Series starter will assure continued reliable and superior performance for many years.

WARNING

The TDI Turbotwin™ T30 Series starter must be installed and operated in accordance with the instructions given in this manual. Failure to properly install the starter, or failure to operate it according to these instructions may result in damage to the starter or the engine, or cause personal injury.

NOTE

THIS STARTER IS TO BE SERVICED ONLY BY AUTHORIZED TDI TURBOTWIN™ DISTRIBUTORS, DEALERS, AND REPAIR STATIONS. DO NOT OPERATE THIS STARTER UNLESS IT IS PROPERLY ATTACHED TO AN ENGINE.

2.0 ORIENTATION OF THE STARTER

If the factory orientation of the starter's pinion housing assembly, gearbox housing assembly, exhaust port (turbine assembly), or inlet housing assembly does not fit your engine installation, these components can be re-oriented.

2.1 MODEL T30-Y ORIENTATION

A. Determine the required orientation of the flange assembly, gearbox assembly, and any optional exhaust port.

B. Note that the mounting flange assembly can be rotated to twelve different positions relative to the gearbox assembly (control ports) and the gearbox housing assembly can be rotated to four positions relative to the inlet port. Additionally, the optional exhaust housing can be rotated to eight positions relative to the inlet port.

CAUTION

All screw threads are treated at the factory with a fastener retention compound. Every screw and tapped hole must be clean and have a drop of Loctite 290 applied to the threads before being reinstalled.

2.1.1 Pinion Housing Assembly Re-Orientation

Remove the twelve mounting flange attachment socket head cap screws.

Rotate the mounting flange to the desired position and reinstall the twelve socket head cap screws. Torque the twelve screws to **9.4 Lb-Ft. (12.7 Nm)**.

CAUTION

Ensure that the O-ring on the mounting flange remains in position and is not cut.

2.1.2 Gearbox Assembly Re-Orientation

Remove the four tie bolts that secure the gearbox assembly to the inlet assembly.

Rotate the gearbox housing / pinion housing assembly to the desired position.

WARNING

Do not remove the five radial screws that connect the inlet and turbine housing. The inlet and turbine housing assembly must remain in the same position, relative to each other.

CAUTION

Ensure that the O-ring on the gearbox assembly remains in position and is not cut.

Reinstall the four tie bolts. Torque the four tie bolts to **9.4 Lb-Ft. (12.7 Nm)**.

CAUTION

Because of the length of the tie bolts, too much torque may weaken or break them. **DO NOT OVER-TORQUE.**

2.1.3 Inlet Assembly Orientation

Refer to Section 2.1.2.

After removing the four tie bolts, rotate the inlet assembly to the desired position relative to the control ports on the gearbox. Align the components and reassemble per Section 2.1.2.

CAUTION

Ensure that the O-ring on the gearbox assembly remains in position and is not cut.

2.2 Model T30-U Flange Mount Orientation

A. Determine the required orientation of the flange assembly, gearbox assembly, and any optional exhaust port.

B. Note that the mounting flange assembly can be rotated to twelve different positions relative to the gearbox assembly (control ports) and the gearbox housing assembly can be rotated to four positions relative to the inlet port. Additionally, the optional exhaust housing can be rotated to eight positions relative to the inlet port.

CAUTION

All screw threads are treated at the factory with a fastener retention compound. Every screw and tapped hole must be clean and have a drop of Loctite 290 applied to the threads before being reinstalled.

2.2.1 Mounting Flange Re-Orientation

Remove the twelve mounting flange to pinion housing assembly socket head cap screws.

Rotate the mounting flange to the desired position and reinstall the twelve cap screws. Torque the twelve screws to **9.4 Lb-Ft. (12.7 Nm)**.

CAUTION

Ensure that the O-ring on the pinion housing remains in position and is not cut.

2.2.2 Gearbox Assembly Re-Orientation

Remove the four tie bolts that secure the gearbox housing assembly to the inlet assembly.

Rotate the gearbox housing and pinion housings assembly to the desired position.

WARNING

Do not remove the five radial screws that connect the inlet and turbine housing. The inlet and turbine housing assembly must remain in the same position, relative to each other.

CAUTION

Ensure that the O-ring on the gearbox housing assembly remain in position and is not cut.

Reinstall the four tie bolts. Torque the four tie bolts to **9.4 Lb-Ft. (12.7 Nm)**.

CAUTION

Because of the length of the tie bolts, too much torque may weaken or break them. **DO NOT OVER-TORQUE.**

2.2.3 Inlet Housing Assembly Re-Orientation

Refer to Section 2.2.2.

After removing the four tie bolts, rotate the inlet assembly to the desired position relative to the gearbox control ports. Align the components and reassemble per Section 2.2.2.

CAUTION

Ensure that the O-ring on the gearbox assembly remains in position and is not cut.

3.0 INSTALLING THE STARTER

A Typical T30 Series installation is shown in Figure 2. The components illustrated may vary in shape, but there must at least be a start switch, air tank, and air piloted relay valve to correctly operate a T30 Series starter.

NOTE

Mounting the air piloted relay valve on the starter is preferred in installations where space is available.

TDI recommends mounting the air piloted relay valve no more than 3 meters (10 feet) from the starter's inlet port, and as close to the starter as possible. If the starter is being installed on a vehicle where the air tank is within 3 meters (10 feet) of the starter, then the relay valve may be mounted on the tank. In installations where the tank is more than 3 meters (10 feet) from the starter, then the relay valve must be mounted within 3 meters (10 feet) of the starter.

A turbine driven starter does not require lubrication in the supply air. Therefore, if a vane-type starter motor is being replaced, TDI recommends that all lubrication devices and lines be removed to minimize flow restrictions.

WARNING

If a fuel (pulse) lubricator has previously been installed in the system, disconnect and plug the line to eliminate spraying diesel fuel on the engine.

Liberal grease the starter's pinion teeth with chassis lube and then mount the T30 Series starter on the engine. Tighten all mounting hardware as appropriate.

After mounting the starter to the engine, attach the supply air line from the tank, the control air lines, and the solenoid to the ignition system and air piloted relay valve.

TDI recommends installation of a "Glad Hand" / quick disconnect for auxiliary pressurization of the air tank.

TDI **TURBOTWIN**™

FROM TECH DEVELOPMENT

Because turbine starters such as the T30 Series are sensitive to flow restrictions, care must be taken to use uniform hose or tubing and fittings for connection of the supply air line. Tees, elbows, and line length must be kept to a minimum. TDI recommends that hose or flex couplings be installed to eliminate possible leakage caused by strain on the supply air line.

Normally an air strainer is not required. In dirty environments, use of a #40 mesh Y-strainer is recommended.

Only type approved metallic hose assemblies are approved in permanently pressurized compressed air lines of starters. Non-metallic hose assemblies are allowed only in case the piping system will be emptied after the starting procedure.

Pipe unions must be type approved by GL. Downstream of the pressure regulator a pressure relief valve is to be provided.

WARNING

Recheck all connections for tight fit.

Fill the air system tank. The T30 Series starter is now ready to operate.

4.0 STARTER OPERATION

The maximum operating pressure limit is the inlet pressure when measured at the starter inlet pressure check port during the crank cycle. In order to check the starter inlet pressure, a 1/8" NPT pipe tap connection is provided in the inlet housing to attach a pressure gauge. Refer to figure 1. **IN NO CASE SHOULD INLET OPERATING PRESSURE EXCEED 10.3 BAR (150 PSIG).**

WARNING

Do not operate the TDI Turbotwin T30 Series air starter with air pressure greater than the pressure rating on the nameplate. This pressure is to be measured at the starter inlet while the starter is running.

The static supply pressure will always be higher than the operating pressure. As a

guideline, the maximum pressure limit (proof pressure) that the T30 Series starter may be subjected to is 20.7 Bar (300 PSIG). System pressure that exceeds the maximum operating limit must use a pressure reducer device to ensure that the operating pressure limit to the T30 Series starter is maintained.

System pressure that exceeds the 20.7 Bar (300 PSIG) limit must, in addition to a pressure reducer device, incorporate a pressure relief valve set below 20.7 Bar (300 PSIG) in the supply air line.

All appropriate local pressure codes and pressure limitations on other system components must be adhered to and would supersede the guidelines given in this manual.

Follow the engine manufacturer's instructions for starting the engine.

WARNING

Do not engage the starter while the engine is running.

If the starter fails to function properly when first operated, or its performance deteriorates with use, refer to the Operator's Trouble Shooting Guide, Section 6.0. If you cannot solve the problem, or repair is necessary, contact your local TDI Turbotwin™ distributor or dealer.

TDI turbine starters share a common characteristic known as "coast-down". Once unloaded, turbines must coast to a stop from their unloaded or *free-speed*. Turbines behave differently in this respect, when compared to positive displacement devices, because the friction (drag) of rubbing,

sealing surfaces (piston rings or vanes) quickly stops an unloaded machine. Less encumbered by drag, and typically decelerating from much higher operating speeds, turbines can take considerably longer to come to rest.

When pre-engaged starters are used, a procedure specifying a 30-second delay between engine crank attempts would be sufficient to insure correct operation. This is

common practice by many customers and such delays are typically programmed into fully automated starter control systems found on many packages.

This "**30 Second Rule**" should also be strictly followed when using the starter in a "manual mode" or to perform routine maintenance tasks such as engine timing, inspections, valve adjustments, etc.

WARNING

Re-engaging pre-engaged turbine starters during coast-down could damage the starter pinion and the engine ring gear. Turbine air starters must **NEVER** be re-engaged during coast-down or before the starter comes to a complete stop.

To insure correct starter operation, customers may choose to incorporate an electronic or pneumatic control device to prevent accidental re-engagement during coast-down. In addition, operators and technicians should be educated about the effects of coast-down.

CAUTION

The grease used in the planetary system has a shelf life of 2 years. Therefore, if the starter is **NOT** installed and operated on the engine for 2 years after the starter is manufactured, the grease should be replaced prior to starter operation. The manufactured date is reflected in the starter serial number. (Ex: 0602-0567 has a manufactured date of February 2006).

5.0 WARRANTY

TDI TURBOTWIN ENGINE STARTER WARRANTY

Tech Development Inc. (TDI) warrants to the original user of the TDI TurboTwin™ Model T30 Series air starters to be free from defects in material and workmanship for a period of one year from date of purchase by such user. The warranty period shall begin on the actual delivery date to the original user or twelve (12) months from the date of shipment from TDI, whichever comes first. The conditions of this warranty are: **a)** TDI is notified within this period by return of such product to TDI or its authorized distributor or dealer, transportation prepaid by user; **b)** such product has been installed according to TDI's specifications; **c)** such product has not been misused, abused or improperly maintained by user; **d)** the defect is not the result of normal wear and tear; and **e)** such starter product has not been repaired with parts not manufactured or authorized by TDI, and TDI installation and repair procedures as outlined in the appropriate manual were properly followed.

Tech Development Inc. shall, at its option, either repair or replace, without charge, any such starter product found by TDI's examination to be defective, or by mutual agreement, refund the user's purchase price in exchange for such starter product. Repairs or replacements are warranted for the remainder of the original warranty period.

Tech Development Inc. makes no other warranty, and IMPLIED WARRANTIES INCLUDING ANY WARRANTY OR MERCHANTABILITY OR FITNESS FOR A PARTICULAR PURPOSE ARE HEREBY DISCLAIMED.

This warranty constitutes the entire obligation of Tech Development Inc. relating to the sale and use of such product, and TDI's maximum liability is limited to the purchase price of such product at the date of purchase. In no event shall TDI be liable for incidental, indirect, consequential or special damages of any nature arising from the sale or use of such engine starter product.

6.0 OPERATOR'S TROUBLESHOOTING GUIDE

TROUBLE	PROBABLE CAUSE	SOLUTION
1. Air always flow through exhaust	A. Relay valve improperly installed.	A. Check typical installation diagram and correct
	B. Relay valve not sealing properly.	B. Check for damaged sealing ring, replace relay valve or damaged parts.
	C. Solenoid is not sealing, pressure remains in APP port of relay valve.	C. Check solenoid potential at the lead to ground should be 0. If not, fix ignition switch problem.
2. Starter engages but does not run,	A. Bad relay valve	A. Replace relay valve.
3. Starter does not run, small air flow from turbine exhaust or drive housing.	A. Nozzle blockage.	A. Remove blockage or obstruction from nozzles.
4. Starter does not run. Normal air flow from exhaust.	A. Excessive bends in the supply line.	A. Shorten length or straighten supply air line.
5. Pinion does not engage	A. Air pressure is too low	A. Increase air pressure to 40 -150 psig.
	B. Control lines to starter ports reversed.	B. Check installation diagram and correct.
	C. Solenoid valve not operating or plugged.	C. Check wiring and solenoid operation. Correct wiring, remove blockage, or replace solenoid valve as needed.
	D. Damaged pinion teeth.	D. Replace pinion or starter drive as necessary.
6. Starter runs but engine cranks slowly or not at all.	A. Air pressure too low	A. Increase air pressure to 40 -150 psig.
	B. Excessive back pressure.	B. Check Exhaust Closure Plate.
	C. Worn or broken starter drive.	C. Replace starter drive.
	D. Nozzle blocked or damaged.	D. Remove blockage or replace damaged parts.
7. Starter continues to operate after start button is released.	A. Solenoid valve is not sealing correctly.	A. See 1C above
	B. Relay valve is not sealing correctly.	B. See 1B above
8. Air tank pressure decays after extended shut down.	A. Air connections are too tight.	A. Tighten loose fittings. Repair or replace damaged fittings.
	B. Damaged air lines: crushed, frayed, kinked.	B. Replace damaged lines.
	C. Relay valve is not sealing correctly.	C. See 1B above
	D. Solenoid valve is stuck open.	D. See 1C above

TDI TURBOTWIN™

FROM TECH DEVELOPMENT

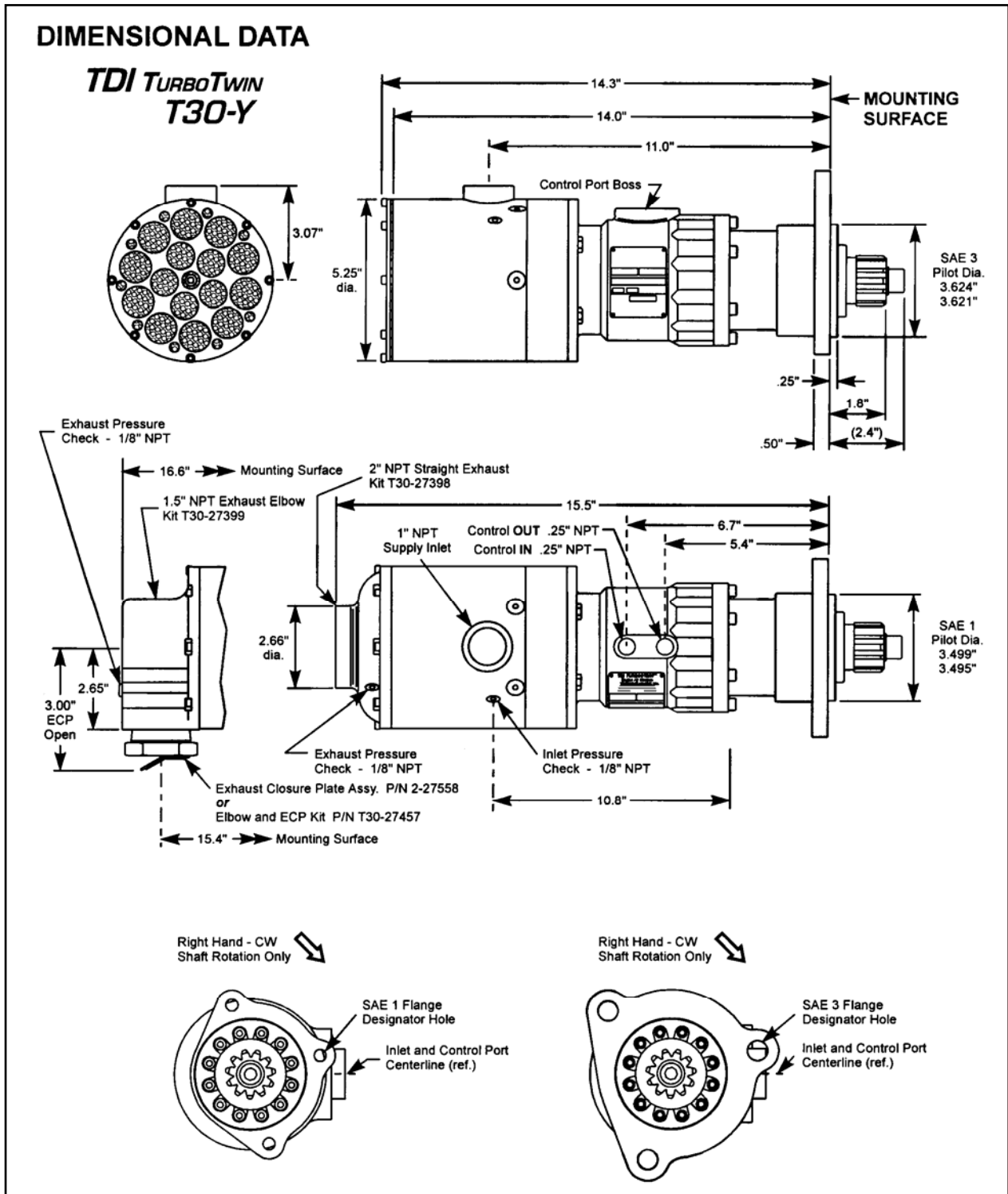

Figure 1. T30-Y TurboTwin Air Starter Envelope Drawing

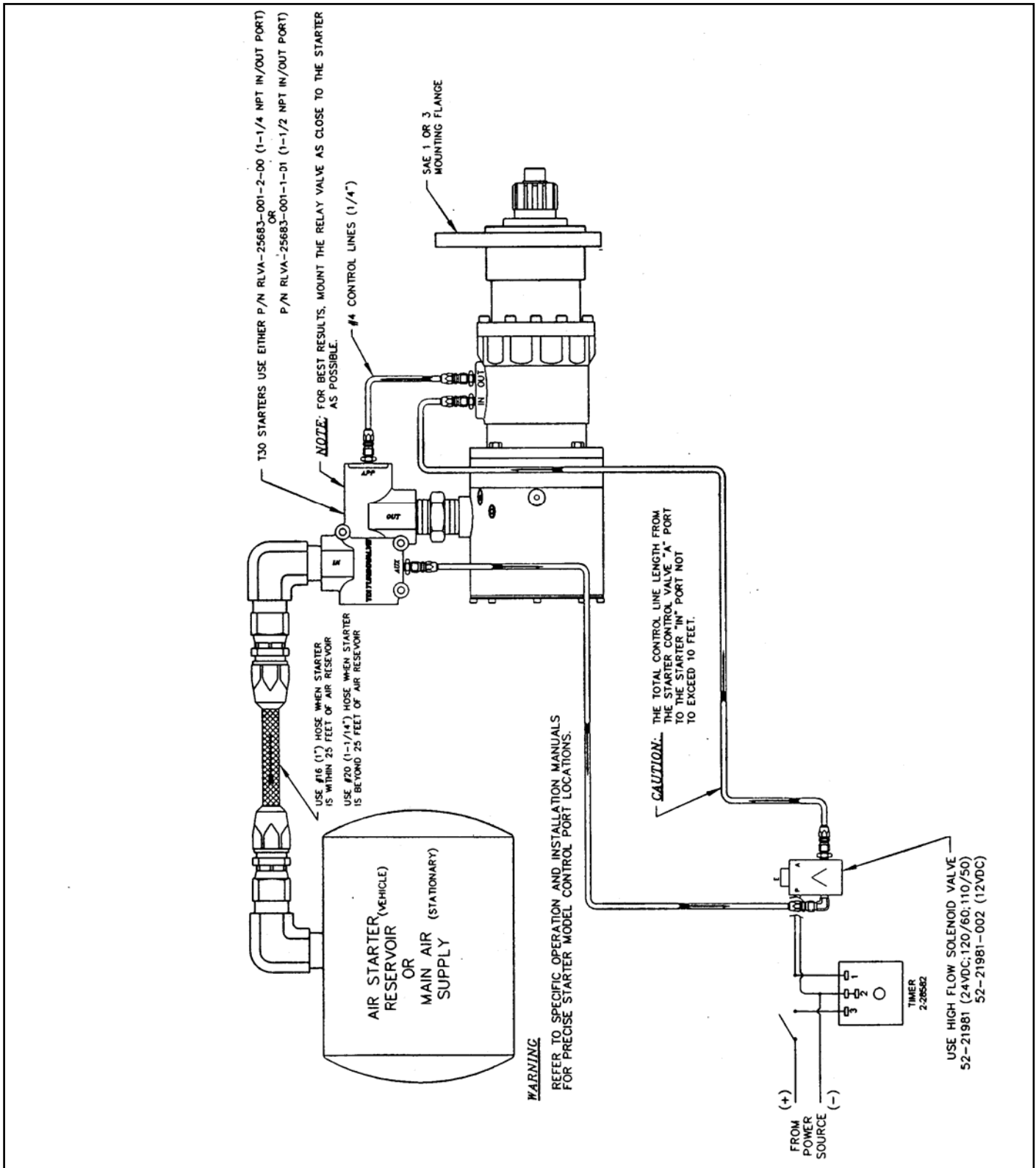

Figure 2. T30-Y TurboTwin Air Starter Installation Diagram

T306 Performance Curve

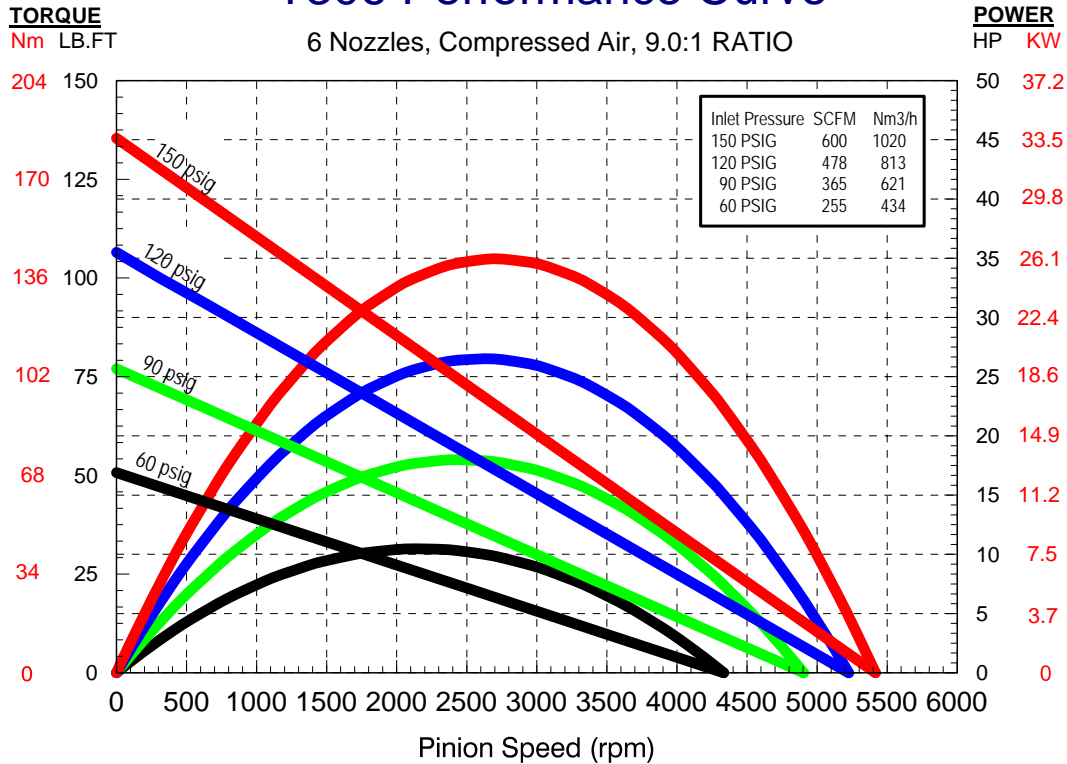

Figure 3. T30-Y TurboTwin Air Starter Performance Curve (Air)

T306 Performance Curve

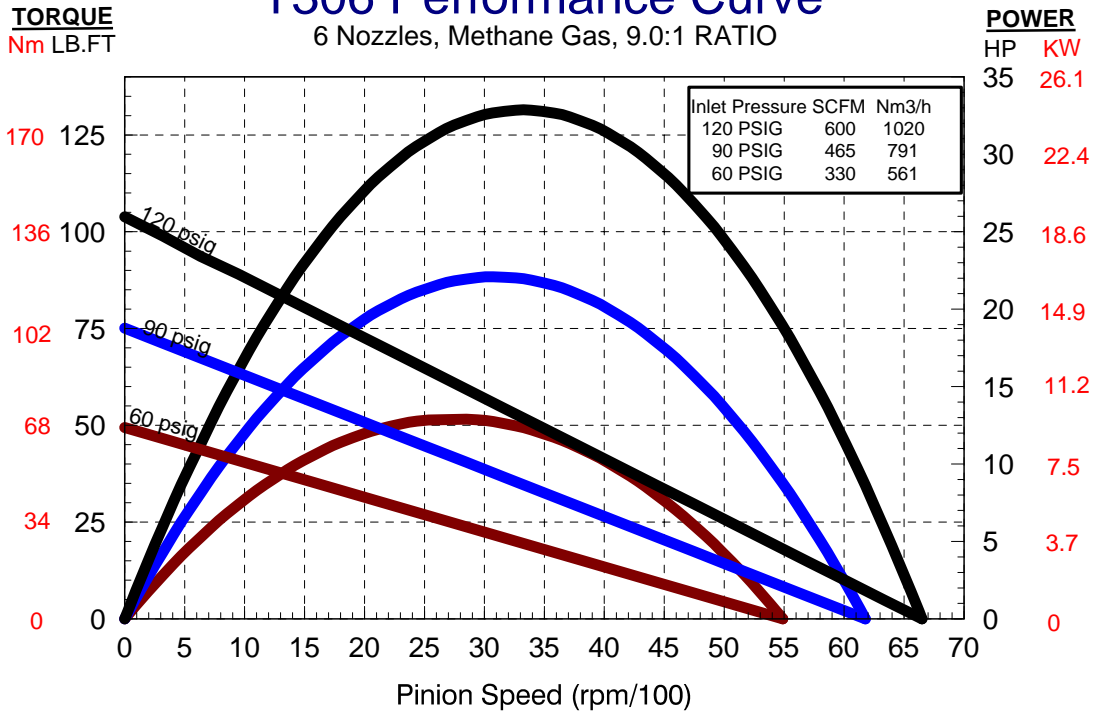

Figure 4. T30-Y TurboTwin Air Starter Performance Curve (Gas)